

SENTINEL II AIRBEAM STRUCTURES

The Sentinel II Airbeam tented structure erects in less than six minutes with no major tools and minimal labor. The Airbeam is available in four sizes and four colors. The Airbeam's rapid deployment configuration is ideal for military training, emergency shelters, commercial/industrial support, or for staff support at special events. The Airbeam is modular and scalable and can be complexed together to establish larger facilities to fit site and customer specific requirements.



KEY FEATURES

- Ready for use in less than 10 minutes
- Lightweight frame system allows for placement and movement by two people
- Modular – connect multiple shelter in different directions
- Maximum interior space due to vertical sidewalls



SPECIFICATIONS

FEATURES

- All weather inflator and hose kit
- Sealed vinyl floor
- Roof vents enable airflow/reduce condensation
- Flame retardant vinyl
- LED lighting

ADDITIONAL ITEMS

- HVAC unit
- Modular composite flooring
- Power generators
- Containerized showers, latrines, laundries, kitchens

WIND LOAD

- 55mph/Gust to 65mph -(89km/h Gust to 105km/h)

ENVIRONMENT

- 20 to 135 F (-29 to 57 C)

SENTINEL II-3 SET UP TIME

4 min

SENTINEL II-3 FOOTPRINT

16'11" x 18'4" (5.2 x 5.8m)

SENTINEL II-3 ARCHES/BEAMS

3

SENTINEL II-3 PEAK

9'2"

SENTINEL II-3 AREA

312 sf (95 sm)

SENTINEL II-3 TOTAL WEIGHT

431 lb (195 kg)

SENTINEL II-3 PACKED DIMENSIONS

Tent: 47" x 39" x 26" (1.2 x 1.0 x 0.7m) Tents/20' Container: 15

SENTINEL II-4 SET UP TIME

5 min

SENTINEL II-4 FOOTPRINT

24'9" x 18'4" (7.4 x 5.8m)

SENTINEL II-4 ARCHES/BEAMS

4

SENTINEL II AIRBEAM STRUCTURE
SENTINEL II-5
TOP VIEW

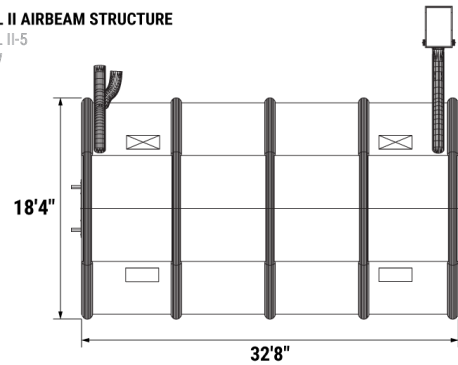

SENTINEL II AIRBEAM STRUCTURE
SENTINEL II-5
RIGHT SIDE VIEW

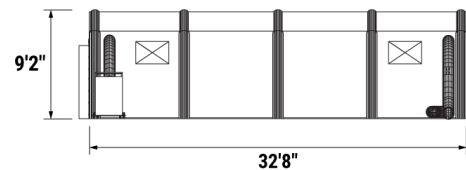

SENTINEL II AIRBEAM STRUCTURE
SENTINEL II-5
FRONT VIEW

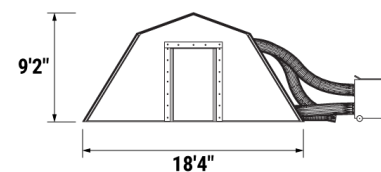

SENTINEL II-4 PEAK	9'2"
SENTINEL II-4 AREA	452 sf (137.8 sm)
SENTINEL II-4 TOTAL WEIGHT	536 lbs (243.2 kg)
SENTINEL II-4 PACKED DIMENSIONS	Tent: 51" x 39" x 28" (1.3 x 1.0 x 0.7m) Tents/20' Container: 15
SENTINEL II-5 SET UP TIME	6 min
SENTINEL II-5 FOOTPRINT	32'8" x 18'4" (10.0 x 5.8m)
SENTINEL II-5 ARCHES/BEAMS	5
SENTINEL II-5 PEAK	9'2"
SENTINEL II-5 AREA	603 sf (183.8 sm)
SENTINEL II-5 TOTAL WEIGHT	640 lb (290.3 kg)
SENTINEL II-5 PACKED DIMENSIONS	Tent: 55" x 39" x 30" (1.4 x 1.0 x 0.8m) Tents/20' Container: 12
SENTINEL II-6 SET UP TIME	6 min
SENTINEL II-6 FOOTPRINT	40'6" x 20'8" (12.4 x 5.8m)
SENTINEL II-6 ARCHES/BEAMS	6
SENTINEL II-6 PEAK	10'2"
SENTINEL II-6 AREA	840 sf (258 sm)
SENTINEL II-6 TOTAL WEIGHT	765 lb (347 kg)
SENTINEL II-6 PACKED DIMENSIONS	Tent: 59" x 39" x 35" (1.5 x 1.0 x 0.9m) Tents/20' Container: 10

COLOR OPTIONS

 Sand

White

 Forest

 Orange

Specifications may vary.

Contact Deployed Resources
for more information.



Contract Holder

315.281.0039 | info@deployedresources.com | deployedresources.com

