

# BICON SHOWER UNIT

Designed for field operations, our Bicon Shower Units (BSUs) provide basic amenities inside a rugged 10' ISO container. Each unit includes interior lighting, sinks, ventilation, and privacy walls.

Units can be operated independently or combined with additional shower units to support larger events. They can be positioned on the ground or left on the chassis for added flexibility. BSUs are ideal for military exercises, special events, or disaster relief operations.

## KEY FEATURES

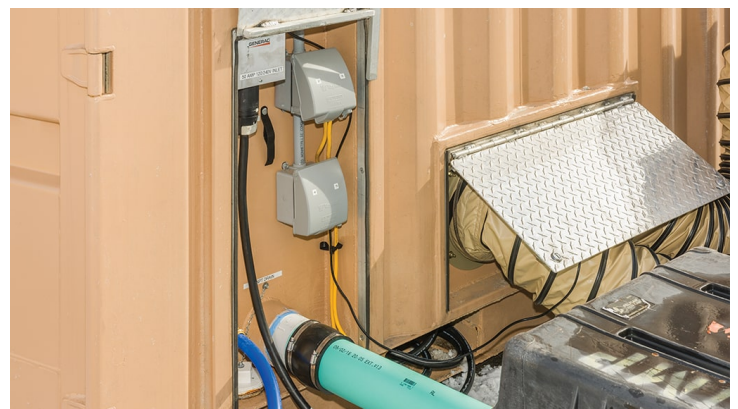

- Interior Lighting
- Sinks
- Ventilation
- Privacy Walls



## SPECIFICATIONS

<b>SIZE</b>	8'W x 8'6"H x 10'D
<b>FOOTPRINT</b>	8' x 10'
<b>WEIGHT</b>	4,280 lbs
<b>WATER INLET</b>	1" NPT
<b>POWER</b>	50A 220V Plug
<b>HVAC</b>	External DI-1.25HP-E w/10" Duct Work
<b>WATER HEATER</b>	80 Gallon – Electric
<b>SHOWERS</b>	3
<b>SINKS</b>	2

## COLOR OPTIONS

-  Sand
-  Custom

Specifications may vary.

Contact [Deployed Resources](https://www.deployedresources.com) for more information.

**BICON SHOWER UNIT**  
LEFT SIDE VIEW

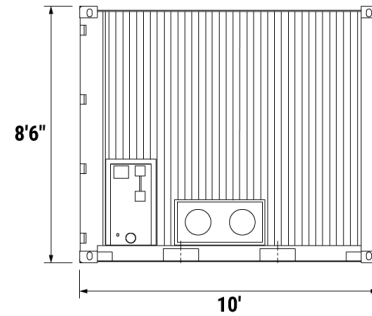

**BICON SHOWER UNIT**  
FRONT VIEW

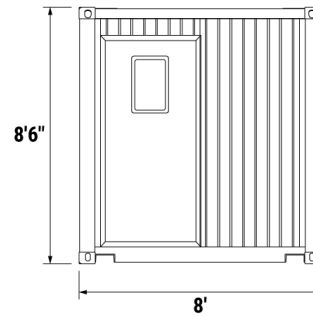

**BICON SHOWER UNIT**

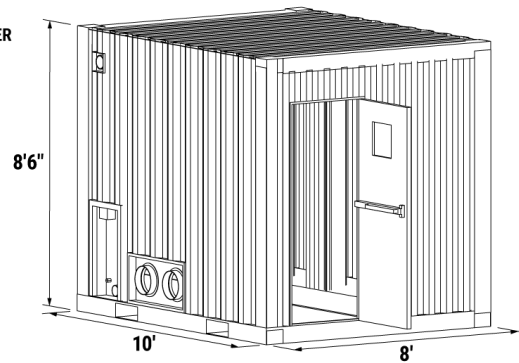

Contract Holder

